

REFERENCIA	FIG	D	L	L1	ADAPTABLE
2A-CC-190	5				PEGASO
2A-CC-191	5				PEGASO
2A-CC-801	9				Cruz Palier Mercedes pasante (269.30)
2A-CC-800	9				Cruz Palier Mercedes roscada (269.30)
2A-CC-1538	1	15	38		Nudo de dirección
2A-CC-1540	1	15	40		Nudo de dirección
2A-CC-410	1	15	41		Cruz Serie GWB 473.10
2A-CC-1638	1	16	38		Nudo de dirección
2A-CC-1639	1	16	38,9		FIAT ALLIS
2A-CC-1640	1	16	40		Nudo de dirección
2A-CC-1644	1	16	44		Cruz
2A-CC-1741	1	17	41		Serie Especial 105.010
2A-CC-1742	1	17,24	41,8		Cruz (1570)
2A-CC-1847	1	18	46,5		Nudos 2A-10.750/1-PEGASO (3200)
2A-CC-1847-1	1	18	47		Cruz
2A-CC-1855	1	18	55		Cruz
2A-CC-1944	1	19	44		Nudo de dirección
2A-CC-1946	1	19	46		Cruz
2A-CC-1947	1	19	47		Cruz
2A-CC-1948	1	19	48		Nudo de dirección y Uso Agrícola
2A-CC-1949	1	19	49		Nudo de dirección 2A-95.901-PEGASO
2A-CC-420	1	19	49,2		Cruz Serie GWB 473.20
2A-CC-1952	1	19	52		Cruz
2A-CC-1954	1	19	54,4		Cruz
2A-CC-105	1	19,05	51,9		Cruz Serie 0500 (2150)
2A-CC-2035R	3	20		35	NISSAN
2A-CC-2041	1	20	41		Cruz
2A-CC-2044	1	20	44		Motocultor PASCUALI
2A-CC-2052	1	20	52		Cruz
2A-CC-2055	1	20	55		MITSUBISHI
2A-CC-2057	1	20	57		TOYOTA
2A-CC-2060	1	20	59,8		SUZUKI
2A-CC-2056	1	20,5	56,6		NISSAN & ISUZU
2A-CC-2249	1	22	49		Moto GUZZI
2A-CC-2250	1	22	50,2		Cruz Serie GWB 373.20
2A-CC-2252	1	22	52		BENATI-FIAT ALLIS y Uso Agrícola
2A-CC-2254	1	22	54		Uso Agrícola
2A-CC-2255	1	22	54,8		Uso Agrícola (30125)
2A-CC-2257	1	22	57		TOYOTA COROLLA
2A-CC-2258	1	22	58		Serie Especial 107.010
2A-CC-430	1	22	59		Cruz Serie GWB 473.30
2A-CC-2260	1	22	60		Cruz NISSAN VANETTE
2A-CC-2262	1	22	62		FORD & LEYLAND
2A-CC-2263	1	22	63,5		FORD ESCORT, CAPRI, CORTINA
2A-CC-2267	1	22	67,5		FORD ESCORT, CAPRI, CORTINA
2A-CC-2235R	3	22,5		34,65	DAIHATSU y MAZDA
2A-CC-2358	1	23,04	58,2		Cruz
2A-CC-2435R	3	23,8		35	Cruz Obra Pública y mov.de tierra
2A-CC-2460	1	23,8	59,4		Cruz PEUGEOT 505-hueca-y Uso Agrícola
2A-CC-110	1	23,81	61,2		Cruz Serie 1100
2A-CC-110-1	1	23,81	61,2		SUZUKI J4x4 J-410/3 & SAMURAI-E.Cen
2A-CC-110-2	1	23,81	61,2		Cruz Serie 1100- sin engrase

FIGURAS 5 y 6 VER PRINCIPALMENTE EN PAG.11-12-13-14-15

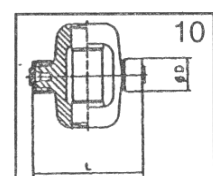
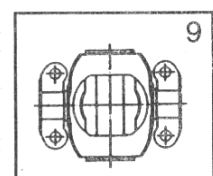
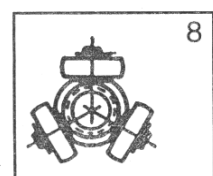
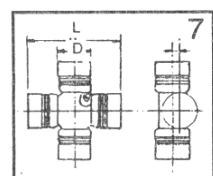
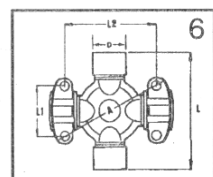
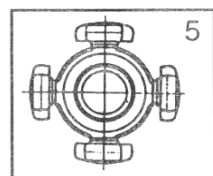
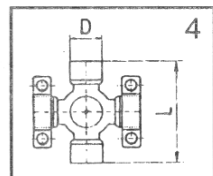
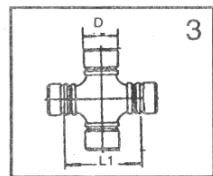
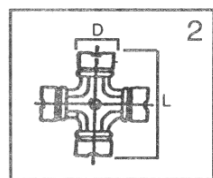
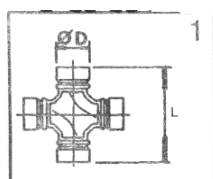

REFERENCIA	FIG	D	L	L1	ADAPTABLE
2A-CC-110-3	1	23,81	61,2		Cruz Serie 1100- hueca y sin engrase (1161)
2A-CC-110-4	1	23,81	61,2		Cruz Serie 1100- sin engrase
2A-CC-2457-1	1	23,83	56,5		Cruz
2A-CC-2434R	3	24		34,4	OPEL KADETT
2A-CC-2440R	3	24		40	NISSAN & ISUZU (2161)
2A-CC-2461	1	24	61		Uso AGRÍCOLA (1230)
2A-CC-2462	1	24	62,5		BMW- con engrase
2A-CC-2463	1	24	63,3		ALFA ROMEO
2A-CC-2465	1	24	65		Cruz
2A-CC-2466	1	24	66		Uso Industrial y Agrícola-FIAT ALLIS
2A-CC-2474	1	24	74,5		BMW-MERCEDES- con engrase
2A-CC-2532R	3	24,6		31,9	Cruz
2A-CC-2534R	3	24,6		34	Cruz Obra Pública y Automoción
2A-CC-2540R	3	24,6		39,5	Cruz Obra Pública y Automoción
2A-CC-2539R	3	25		38,8	SUZUKI
2A-CC-2540R-1	3	25		40	NISSAN
2A-CC-2541R	3	25		41,2	MAZDA
2A-CC-2545R	3	25		45,5	SUZUKI
2A-CC-2557	1	25	57		CITROËN 2 CV (1260)
2A-CC-2564	1	25	64		SUZUKI,MAZ,HND,MITSH,DAIT-E.late.
2A-CC-2576	1	25	76,5		MITSUBISHI
2A-CC-2578	1	25	77,8		MITSUBISHI
2A-CC-2576-1	1	25,1	76		MITSUBISHI
2A-CC-2539R	3	25,4		39,3	Cruz Obra Pública y Automoción
2A-CC-2541R-1	3	25,4		41,3	Cruz Obra Pública y Automoción
2A-CC-2555R	3	25,4		55	Cruz Obra Pública y Automoción
2A-CC-2556R	3	25,4		55,9	Cruz Obra Pública y Automoción
2A-CC-25	8	25,5			Cruz SEAT 127-Tripode (30139)
2A-CC-2642R	3	26		42	TOYOTA
2A-CC-2645R	3	26		45,2	MERCEDES 180-190-219-220-Eng.central
2A-CC-2653R	3	26		53,4	TOYOTA
2A-CC-200	1	26	69,8		Serie 287.00 y Furg.MERC.410-Eng.central
2A-CC-2682	1	26	82		Cruz
2A-CC-2668	1	26,15	68		Cruz
2A-CC-2743R-1	3	26,5		43	Cruz (3002)
2A-CC-2748R	3	26,52		48	Cruz Obra Pública y Automoción-MAZDA
2A-CC-130	1	26,98	74,4		Serie 1300-Engrase lateral
2A-CC-130-1	1	26,98	74,4		Serie 1300-Engrase central y Uso Agrícola
2A-CC-130-2	1	26,98	74,4		MORRIS 110-1300 45
2A-CC-130-SR	1	26,98	74,4		Serie 1300-Palier LAND ROVER-sin reten
2A-CC-131	1	26,98	81,7		Cruz Serie 1310-Engrase lateral
2A-CC-138	1	26,98	84,4		EBRO F 260- maciza
2A-CC-139	1	26,98	84,4		EBRO F 100,F 108 y F 260- hueca
2A-CC-2743R	3	27		43	Cruz Obra Pública y Automoción
2A-CC-2746R	3	27		46	ROCKWELL
2A-CC-2752R	3	27		51,7	JEEP-Cruz diferencial-sin retenes
2A-CC-2753R	3	27		52,5	Cruz-con retenes
2A-CC-2757R	3	27		57,2	CHEVROLET
2A-CC-2767R	3	27		67,5	Cruz Obra Pública y Automoción
2A-CC-2760	1	27	60		Cruz
2A-CC-2762	1	27	61,9		Serie Spicer 1210 y Furg.HYUNDAI-E.cen.
2A-CC-2770	1	27	70		Junta doble y Uso Agrícola

FIGURAS 5 y 6 VER PRINCIPALMENTE EN PAG.11-12-13-14-15

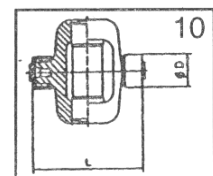
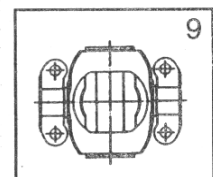
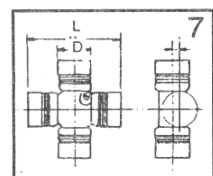
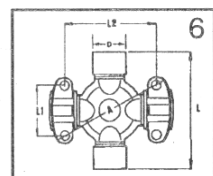
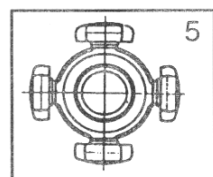
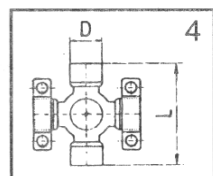
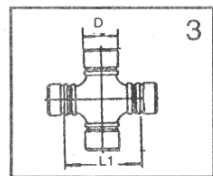
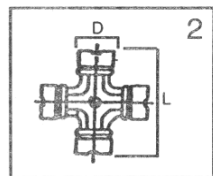
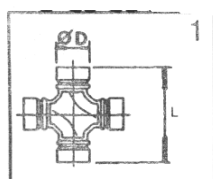

REFERENCIA	FIG	D	L	L1	ADAPTABLE
2A-CC-2771	1	27	71		FORD TRANSIT-Engrasador central
2A-CC-2772	1	27	72		Cruz
2A-CC-2780	1	27	80		Cruz PEGASO EKUS y Furg.HYUN.-E.cen
2A-CC-2781	1	27	81,7		Cruz Serie Spicer 1310-reforzada
2A-CC-2785	1	27	85		Cruz BENATI-reforzada
2A-CC-2792	1	27	92,1		Serie Spicer 1330
2A-CC-2751R	3	27,4		50,8	DODGE 3700 y otros vehiculos (1281)
2A-CC-28	8	27,9			Cruz SEAT 128,RITMO
2A-CC-2844R	3	28		44	Cruz (1284)
2A-CC-2849R	3	28	81	49	MERCEDES (Furg. & Coches-Eng.central
2A-CC-2852R	3	28		52,9	NISSAN-PATROL
2A-CC-2870	1	28	70		Cruz
2A-CC-2871	1	28	71,5		Serie Especial 109.010
2A-CC-2871-1	1	28	71,5		LADA
2A-CC-2874	1	28	74		Cruz
2A-CC-2881	1	28	81		Cruz
2A-CC-2880	1	28,1	80		DAIHATSU
2A-CC-2855R	3	28,5		55,5	TOYOTA 4x4-Engrase dado
2A-CC-2862R	3	28,5		62	DAIHATSU-GM
2A-CC-2865	1	28,5	65		Cruz
2A-CC-2949R-1	3	28,57		49,2	Patrol Nudo Homocinético
2A-CC-2960R	3	28,57		60,3	Patrol Nudo Homocinético
2A-CC-2960R-1	3	28,6		60	Cruz Obra Pública y Automoción
2A-CC-2967	1	28,6	67,2		Cruz Obra Pública y Automoción
2A-CC-2975	1	28,6	74,5		Cruz
2A-CC-2949R	3	29		49	TOYOTA
2A-CC-2950R	3	29		50	ISUZU
2A-CC-2978R	3	29		77,8	Cruz Obra Pública y Automoción
2A-CC-2976	1	29	76		Cruz
2A-CC-2980	1	29	79,6		Cosechadora BERTOLINI,BONDIOLI
2A-CC-2955R	3	29,05		54,7	Cruz (1800)
2A-CC-3055R	3	30		55,1	MITSUBISHI
2A-CC-3057R	3	30		57	ARO 4x4
2A-CC-3074R	3	30		74	MERCEDES y MITSUBISHI (Pajero)
2A-CC-210	1	30	81,8		Cruz Serie GWB 287.10 (2120)
2A-CC-3083	1	30	83		Serie Especial 110.012-Engrase central
2A-CC-3083-1	1	30	83		Serie Especial 110.012-Engrase en dado
2A-CC-3085	1	30	85		Cruz
2A-CC-3086	1	30	86		Cruz
2A-CC-3092	1	30	92		Cruz (Mix)
2A-CC-3097	1	30	97		Cruz Serie Especial 112.012
2A-CC-3078D	7	30	78,5		Cruz ejes desplazados
2A-CC-3079D	7	30	79		Cruz ejes desplazados
2A-CC-30	8	30			Tipo Trípod
2A-CC-3056R	3	30,1		55,5	Cruz JEEP CHEROKEE (en N.H.)
2A-CC-3082	1	30,16	81,8		Cruz Cardan Especial
2A-CC-135	1	30,16	92		Cruz Serie 1350-Engrase lateral
2A-CC-135-1	1	30,16	92		Serie 1350-Uso Agrícola-Engrase central
2A-CC-141	1	30,16	106,6		Cruz Serie 1410-Engrase lateral
2A-CC-141-1	1	30,16	106,6		Cruz Serie 1410-Uso Agrícola-Eng.central
2A-CC-3053R	3	30,2		52,8	Cruz Obra Pública y Automoción
2A-CC-3080	1	30,2	80		Uso Agrícola
2A-CC-3082-1	1	30,2	82		Cruz Serie Compact 2020

FIGURAS 5 y 6 VER PRINCIPALMENTE EN PAG.11-12-13-14-15

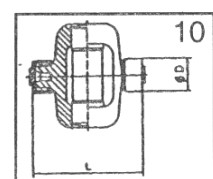
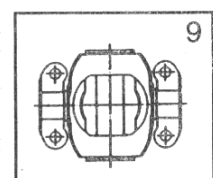
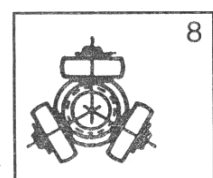
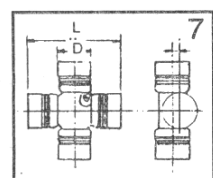
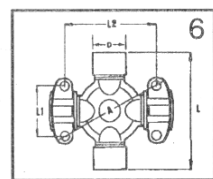
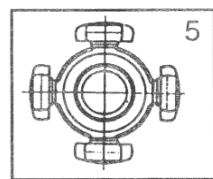
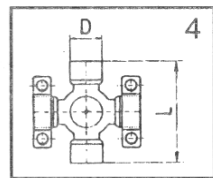
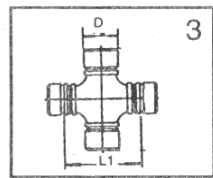
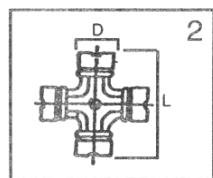
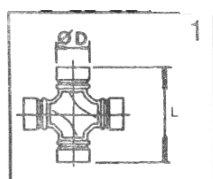

REFERENCIA	FIG	D	L	L1	ADAPTABLE
2A-CC-3144R	1	31		44	FORD TRANSIT (Mod. antiguo)
2A-CC-3151R	3	31		51,05	Cruz
2A-CC-3188	1	31	88		MERCEDES 4x4-G.WAGON
2A-CC-3190	1	31	90		Uso Agrícola
2A-CC-3186	1	31,2	86		Cruz Obra Pública y Automoción
2A-CC-3281	1	31,8	81,5		ROCKWELL
2A-CC-3257R	3	32		57	MAZDA
2A-CC-3261R	3	32		61	TOYOTA
2A-CC-3276	1	32	76		Uso Agrícola
2A-CC-3280	1	32	80		Uso Agrícola
2A-CC-3282D	7	32	82		Cruz ejes desplazados Serie GWB 469.10
2A-CC-3284	1	32	84		Cruz
2A-CC-3286	1	32	86		Uso Agrícola
2A-CC-3290	1	32	90		Cruz
2A-CC-3296	1	32	95,6		BENATI
2A-CC-32106	1	32	106,5		Uso Agrícola
2A-CC-32	8	32			SEAT IBIZA-Tripode (30199)
2A-CC-3380R	3	33,3		79,5	Cruz Obra Pública y Automoción
2A-CC-3451R	3	34		51	Cruz
2A-CC-3456R	3	34		56,5	Uso Agrícola
2A-CC-3488	1	34		88	MERCEDES-UNIMOG
2A-CC-3496D	7	34	96		Cruz ejes desplazados
2A-CC-3497	1	34	97		Serie Especial 112.010
2A-CC-34105	1	34	105		Cruz
2A-CC-34106	1	34	106,5		Uso Agrícola
2A-CC-225	1	34,9	92,2		Cruz Serie Compact 2025
2A-CC-148	1	34,9	106,3		Cruz Serie 1480 Compact 2030
2A-CC-155	1	34,9	126		Cruz Serie 1550
2A-CC-3599R	3	35		99	
2A-CC-3587D	7	35	87		Cruz ejes desplazados
2A-CC-3594	1	35	94		BONDIOLI PAVESI
2A-CC-3595	1	35	95		Cruz
2A-CC-220	1	35	96,8		Cruz Serie GWB 287.20
2A-CC-3596D	7	35	96,8		Cruz ejes desplazados Serie GWB 469.20
2A-CC-3689	1	36	89		Uso Agrícola
2A-CC-3697	2	36	97		FURUKAWA
2A-CC-36110	1	36	110		
2A-CC-36131	1	36	131		Cruz
2A-CC-3856R	3	38		55,8	MERCEDES
2A-CC-320	1	38	105,8		Cruz Serie GWB 387.20
2A-CC-38107D	7	38	107		MERCEDES-ejes desplazados
2A-CC-38110	1	38	110		MAN L-2000
2A-CC-38111	1	38	111		Cruz
2A-CC-38112	1	38	112		Cruz
2A-CC-38119	9	38	119		Cruz Palier IVECO RENAULT
2A-CC-P30	4	38	148		SCANIA P30 y P300 (4,5°) (337058)
2A-CC-P30-1	4	38	148		SCANIA P30 y P300 (0°)
2A-CC-P30-2	1	38	148		SCANIA P30 y P400-sin aletas
2A-CC-38105D	7	38	105		MERCEDES-Cruz ejes despl.GWB 469.30
2A-CC-39110	1	38,9	109,5		Cruz
2A-CC-39148	1	38,9	148		Cruz Obra Pública y Automoción
2A-CC-39116	1	39	116,4		FIAT ALLIS-IVECO

FIGURAS 5 y 6 VER PRINCIPALMENTE EN PAG.11-12-13-14-15

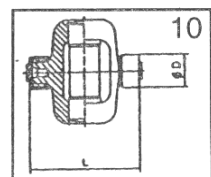
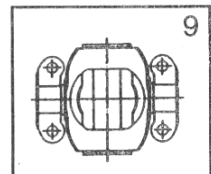
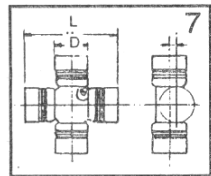
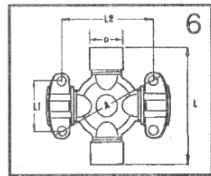
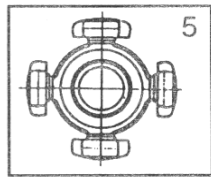
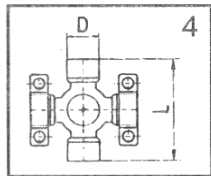
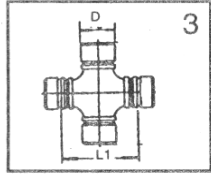
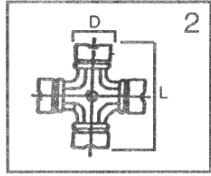
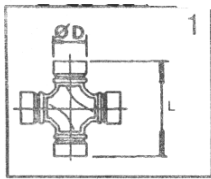

REFERENCIA	FIG	D	L	L1	ADAPTABLE
2A-CC-150	1	39,68	115,9		Serie 1500 (Ariillos)-Adap.Serie 606
2A-CC-150-1	2	39,68	115,9		Cruz Serie 1500 (Chapas)
2A-CC-40104D	7	40	104,3		Cruz ejes desplazados-MERCEDES/MAN
2A-CC-41108	1	41	108		Uso Agrícola
2A-CC-41118	1	41	118		Uso Agrícola
2A-CC-41105R	3	41,3		105	Cruz Obra Pública y Automoción
2A-CC-41104	1	41,3	104		Cruz
2A-CC-41126	1	41,3	126		Cruz Serie Spicer SPL-90
2A-CC-41129	1	41,3	129		Cruz
2A-CC-41140	1	41,3	140		Cruz
2A-CC-41142	1	41,3	142		Cruz Serie Spicer 1650
2A-CC-41117	1	41,5	117		Cruz
2A-CC-4266R	3	42		66	MERCEDES
2A-CC-515	1	42	104,5		Cruz Serie GWB 587.15
2A-CC-42106	1	42	106		MERCEDES
2A-CC-42118	1	42	118		Cruz
2A-CC-235	1	42	119,4		Cruz Serie Compact 2035
2A-CC-42122	1	42	122		Cruz
2A-CC-42123	1	42	123		Serie Especial 115.010
2A-CC-42124	1	42	124		Cruz
2A-CC-42126	1	42	126		Cruz
2A-CC-42133	1	42	133		Serie Especial 115.012-Engrase en dado
2A-CC-42110D	7	42	110		Cruz ejes desplazados
2A-CC-44120	1	44	120		Cruz
2A-CC-230	1	44	124,8		Cruz Serie GWB 287.30
2A-CC-300	1	44	126,2		VOLVO Serie 300 (chapas)
2A-CC-44149	1	44	149		SCANIA-264043
2A-CC-186	1	45	120,4		Cruz Serie GWB 186.30
2A-CC-45121	1	45	121,4		Cruz
2A-CC-45130	1	45	130		Cruz
2A-CC-45131	1	45	131		Cruz
2A-CC-45134	1	45	134		Cruz
2A-CC-45135	1	45	135		Cruz Serie Especial 116.010
2A-CC-45150	1	45	150		Cruz
2A-CC-45152	1	45	152		Serie Especial 118.010
2A-CC-45155	1	45	155		Cruz
2A-CC-45160	1	45	160		Cruz
2A-CC-45125D	7	45	125		Cruz ejes desplazados 515.021
2A-CC-45126D	7	45	126		Cruz ejes desplazados
2A-CC-330	1	47	131		Cruz Serie GWB 387.30
2A-CC-47132	1	47	132		Cruz
2A-CC-47156	1	47	156		TATRA
2A-CC-160	2	47,65	134,9		Cruz Serie 1600 (chapas)
2A-CC-160-A	1	47,65	134,9		Cruz Serie 1600 (arillos) Compact 2040
2A-CC-160-MX	6	47,65	134,9		AUTOCAR RENAULT-TELMA
2A-CC-520	1	48	116,5		Cruz Serie GWB 587.20
2A-CC-286	1	48	126		MERCEDES Serie GWB 286.33
2A-CC-48130	1	48	130		Cruz
2A-CC-48135	1	48	135		Cruz Serie GWB 186.35
2A-CC-P40	4	48	161		SCANIA Ser.P40 y P400 (4,5°)-Freno Elec.
2A-CC-P40-1	4	48	161		SCANIA Serie P40 y P400 (4,5°) (337.059)
2A-CC-P40-2	4	48	161		SCANIA Serie P40 y P400 (0°)

FIGURAS 5 y 6 VER PRINCIPALMENTE EN PAG.11-12-13-14-15

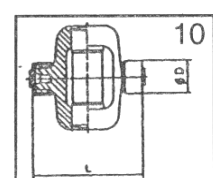
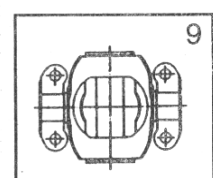
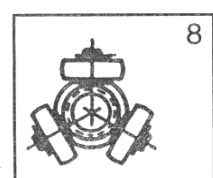
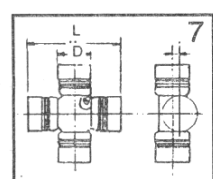
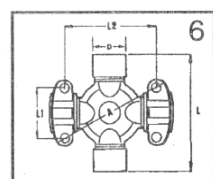
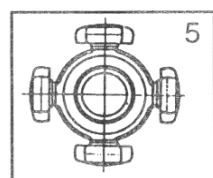
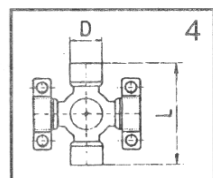
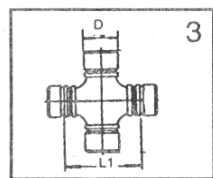
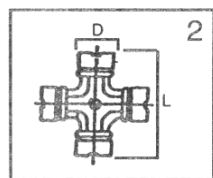
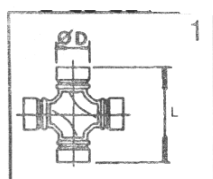

REFERENCIA	FIG	D	L	L1	ADAPTABLE
2A-CC-P40-3	1	48	161		SCANIA-sin aletas
2A-CC-49135	1	49	135		FIAT IVECO
2A-CC-49151	1	49	151		Cruz
2A-CC-49130	2	49,21	130		FIAT ALLIS
2A-CC-170	2	49,21	154,8		Cruz Serie 1700 (chapas)-Engrase central
2A-CC-170-1	2	49,21	154,8		Cruz Serie 1700 (chapas)-Engrase lateral
2A-CC-170-MX	6	49,21	154,8		AUTOCAR RENAULT-TELMA
2A-CC-170-A	1	49,21	154,8		Cruz Serie 1700 (arillos) Compact 2050
2A-CC-176	2	49,21	177,8		Cruz Serie 1760 (Stand.)-chapas soldadas
2A-CC-181	2	49,21	191,5		Cruz 1810-chapas soldadas
2A-CC-181-A	1	49,21	191,5		Cruz Serie 1810-arillos
2A-CC-50131	1	50	131		Cruz Serie GWB 487.30
2A-CC-50152D	7	50	152		Cruz
2A-CC-400	1	50	152,8		VOLVO Serie 400 (chapas)
2A-CC-50154	1	50	154		Cruz
2A-CC-50161	1	50	161		Cruz
2A-CC-50164	1	50	164		IVECO,SCANIA
2A-CC-51151	1	50,8	150,8		Cruz
2A-CC-530	1	52	133		Cruz Serie GWB 587.30 Standard
2A-CC-530-1	1	52	133		Cruz Serie GWB 587.30-Eng en los 4 dados
2A-CC-530-2	1	52	133		Cruz Ser. GWB 587.30-Muñeq.de 35,8 mm
2A-CC-245	1	52	147,2		Cruz Serie Compact 2045
2A-CC-52154	1	52	154		Cruz
2A-CC-52156	1	52	156		Cruz
2A-CC-187	1	53	135		MERCEDES Serie 186.37
2A-CC-55162	1	55	162		Cruz
2A-CC-55164	1	55	164		Cruz Serie GWB 387.40 y Spicer SPL-170
2A-CC-188	2	55,6	206		Cruz Spicer 1880-chapas soldadas
2A-CC-535	1	57	144		Cruz Serie GWB 587.35 Standard
2A-CC-535-1	1	57	144		Cruz Serie GWB 587.35-Eng en los 4 dados
2A-CC-536	1	57	144		Cruz Serie GWB 587.36-Muñeq.de 40,8mm
2A-CC-542	1	57	152		Serie GWB 587.42 Standard-Compact 2055
2A-CC-542-1	1	57	152		Cruz Serie GWB 587.42-Engrase en dados
2A-CC-500/600	1	57	152,6		VOLVO Serie 500 y 600
2A-CC-P50	4	57	164		SCANIA Serie P50 y P500 (4,5°) (337060)
2A-CC-P50-1	4	57	164		SCANIA Serie P50 y P500 (0°)
2A-CC-P50-2	1	57	164		SCANIA Serie P50 y P500-sin aletas
2A-CC-572	1	57	172		IVECO TURBOSTAR
2A-CC-180	2	58,97	167,4		Cruz Serie 1800-chapas soldadas
2A-CC-180-1	2	58,97	167,4		Cruz Serie 1800-chapas sueltas
2A-CC-180-A	1	58,97	167,4		Cruz Serie 1800 (arillos) Compact 2060
2A-CC-180-MX	6	58,97	167,4		AUTOCAR RENAULT-TELMA
2A-CC-60170	1	60	170		IVECO
2A-CC-65144	1	65	144		Cruz Serie GWB 190.50
2A-CC-548	1	65	172		Cruz Serie GWB 587.48
2A-CC-65190	1	65	190		SCANIA Serie P60
2A-CC-360	3	68	166,5	89	MERCEDES ACTROS Serie 385.60
2A-CC-550	1	72	185		Cruz Serie GWB 587.50
2A-CC-74154	1	74	154		Cruz Serie GWB 190.55
2A-CC-74180	1	74	180		WOITH
2A-CC-83175	1	83	175		GWB 190.60
2A-CC-100210	1	100	210		GWB 190.70

FIGURAS 5 y 6 VER PRINCIPALMENTE EN PAG.11-12-13-14-15

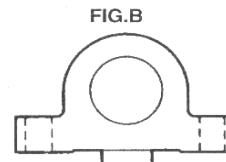
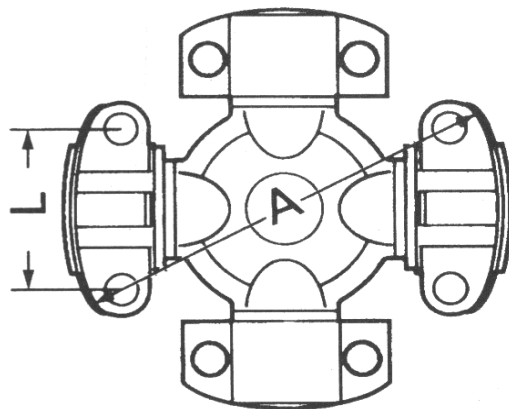

ALETA BAJO PASANTE

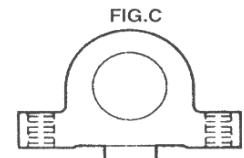

ALETA BAJO ROSCADO

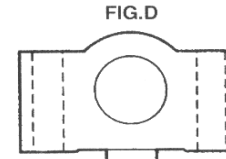

ALETA ALTO PASANTE

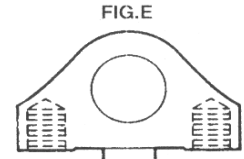

DELTA

REFERENCIA	L	A	SERIE	TIPO	CANT.	FIG	TIPO	CANT	FIG
2A-CR-994	33,3	79,6	Mechanic 2-C	BAJO PASANTE	4	B			
2A-CR-454*	33,3	79,6		BAJO PASANTE	4	B			
2A-CR-952	33,3	79,6		BAJO PASANTE	2	B	BAJO ROSCADO	2	C
2A-CR-452*	33,3	79,6		BAJO PASANTE	2	B	BAJO ROSCADO	2	C
2A-CR-951	33,3	79,6					BAJO ROSCADO	4	C
2A-CR-453*	33,3	79,6					BAJO ROSCADO	4	C
2A-CR-967			Mechanic 3-C	ALTO PASANT.	4	D			
2A-CR-536	36,5	90,5					BAJO ROSCADO	4	C
2A-CR-495	36,5	90,5		BAJO PASANTE	4	B			
2A-CR-535	36,5	90,5		BAJO PASANTE	2	B	BAJO ROSCADO	2	C
2A-CR-969	36,5	108	Mechanic 4-C	ALTO PASANT.	4	D			
2A-CR-921									
2A-CR-549	36,5	108		BAJO PASANTE	4	B			
2A-CR-929	36,5	108		ALTO PASANT.	2	D	BAJO ROSCADO	2	C
2A-CR-541	36,5	108		BAJO PASANTE	2	B	BAJO ROSCADO	2	C
2A-CR-540	36,5	108					BAJO ROSCADO	4	C
2A-CR-996	36,5			BAJO PASANTE	2	B	ALTO PASANTE	2	D
2A-CR-968	42,9	115	Mechanic 5-C	ALTO PASANT.	4	D			
2A-CR-999	42,9	115		BAJO PASANTE	4	B			
2A-CR-552	42,9	115		BAJO PASANTE	2	B	BAJO ROSCADO	2	C
2A-CR-991									
2A-CR-558	42,9	115		ALTO PASANT.	2	D	BAJO PASANTE	2	B
2A-CR-933	42,9	115		ALTO PASANT.	2	D	BAJO ROSCADO	2	C
2A-CR-550	42,9	115				BAJO ROSCADO	4	C	
2A-CR-920									
2A-CR-905	42,9	140	Mechanic 6-C	ALTO PASANT.	4	D			
2A-CR-563	42,9	140		ALTO PASANT.	2	D	BAJO ROSCADO	2	C
2A-CR-943									
2A-CR-560	42,9	140					BAJO ROSCADO	4	C
2A-CR-901-MA	49,2	124,6			ALTO PASANT.	4	D+C		
2A-CR-894-E	49,2	130		ALTO PASANT.	4	D			
2A-CR-486									
2A-CR-894	49,2	135	Rockwell 58 WB	ALTO PASANT.	4	D			
2A-CR-895	49,2	135					DELTA	4	E
2A-CR-896	49,2	135		ALTO PASANT.	2	D	DELTA	2	E

*Engrasador en dado

A = Anclaje

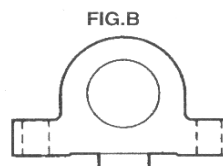
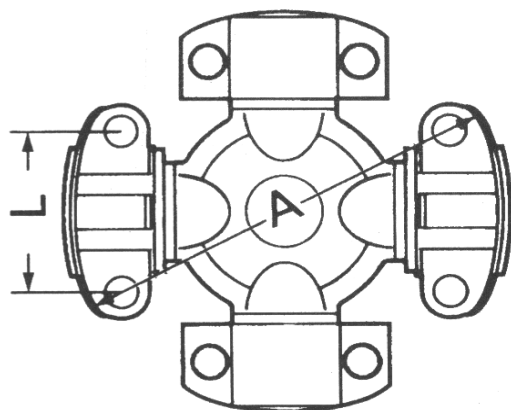

ALETA BAJO PASANTE

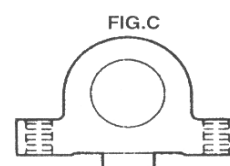

ALETA BAJO ROSCADO

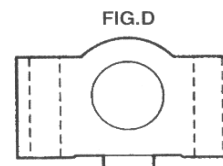

ALETA ALTO PASANTE

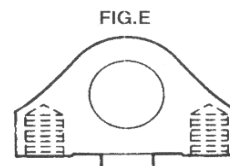

DELTA

REFERENCIA	L	A	SERIE	TIPO	CANT.	FIG	TIPO	CANT	FIG
2A-CR-927	49,2	148,4	7-C	ALTO PASANT.	4	D			
2A-CR-575	49,2	148,4		BAJO PASANTE	4	B			
2A-CR-574	49,2	148,4		ALTO PASANT.	2	D	BAJO ROSCADO	2	C
2A-CR-774	49,2	148,4		ALTO PASANT.	2	D	DELTA	2	E
2A-CR-570	49,2	148,4		BAJO ROSCAD.	4	C			
2A-CR-928	49,2	206,3	8-C	ALTO PASANT.	4	D			
2A-CR-584	49,2	206,3		BAJO PASANTE	4	B			
2A-CR-781	49,2	206,3					DELTA	4	E
2A-CR-583	49,2	206,3		ALTO PASANT.	2	D	DELTA	2	E
2A-CR-909									
2A-CR-582	49,2	206,3		BAJO PASANTE	2	B	BAJO ROSCADO	2	C
2A-CR-913									
2A-CR-581	49,2	206,3		BAJO ROSCAD.	4	C			
2A-CR-910									
2A-CC-191	55	206,3		ALTO ROSCAD.	4	D+C			
2A-CR-963	71,4	165	8,5-C	ALTO PASANT.	4	D			
2A-CR-785	71,4	165					DELTA	4	E
2A-CR-950	71,4	165		ALTO PASANT.	2	D	DELTA	2	E
2A-CR-964-IC	71,4	165		BAJO PASANTE	4	B			
2A-CR-911	71,4	210	9-C	ALTO PASANT.	4	D			
2A-CR-793	71,4	210					DELTA	4	E
2A-CR-792	71,4	210		ALTO PASANT.	2	D	DELTA	2	E
2A-CR-490	89	223,8	11-C	ALTO PASANT.	4	D			
2A-CR-485	92,1	212,5	10-C	ALTO PASANT.	4	D			
2A-CR-988									

*Engrasador en dado

A = Anclaje

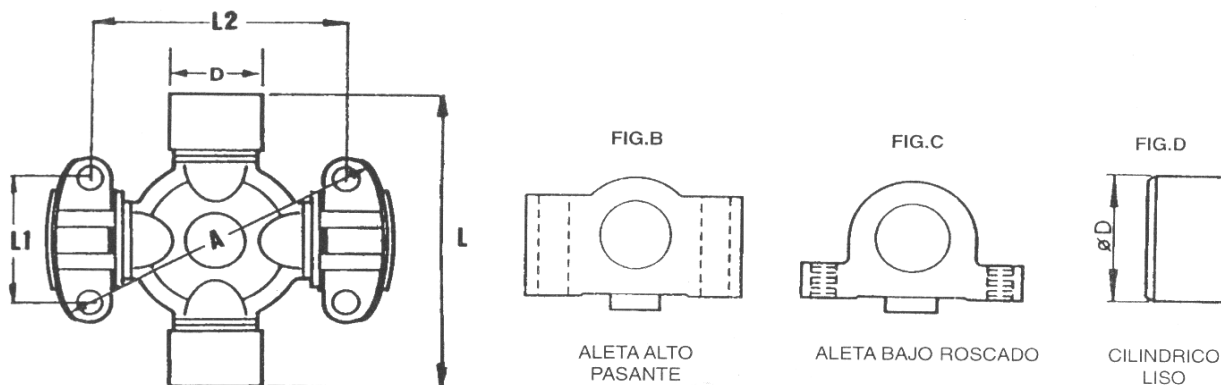

REFERENCIA	SERIE	DADO CILINDRICO LISO			ALETA PASANTE Ó ROSCADO				OBSERVACIONES
		D	L	FIG.	A	L1	L2	FIG.	
2A-CR-141/4C	4C/1410	30,1	106,3	D	107,9	36,7	87	B	2 DADOS PASANTES
2A-CR-141/4C-R		30,1	106,3	D	107,9	36,7	87	C	2 DADOS ROSCADOS
2A-CR-141/5C	5C/1410	30,1	106,3	D	115	42,9	88,9	B	2 DADOS PASANTES
2A-CR-148/5C	5C/1480	34,9	106,3	D	115	42,9	88,9	B	2 DADOS PASANTES
2A-CR-148/5C-R		34,9	106,3	D	115	42,9	88,9	C	2 DADOS ROSCADOS
2A-CR-155/6C	6C/1550	34,9	126,1	D	140,4	42,9	114,3	B	2 DADOS PASANTES
2A-CR-155/6C-R		34,9	126,1	D	140,4	42,9	114,3	C	2 DADOS ROSCADOS
2A-CR-484	6C/Rockwell S8	34,9	126,1	D	134,9	49,2		B	2 DADOS PASANTES
2A-CR-1650/7C	7C/1650	41,3	142	D	148,3	49,2	117,5	B	2 DADOS PASANTES
2A-CR-1650/7C-R		41,3	142	D	148,3	49,2	117,5	C	2 DADOS ROSCADOS
2A-CR-41152/7C		41,3	152	D	148,3	49,2	117,5		FURUKAWA 2 DADOS PASANT.
2A-CR-170/8,5C	8,5C/1710	49,2	191,5	D	165	71,4	123,9	B	2 DADOS PASANTES
2A-CR-181/9C	9C/1810	49,2	191,5	D	209,6	71,4	168,3	B	2 DADOS PASANTES
2A-CR-188/9C	9C/1880	55,6	205,6	D	209,6	71,6	123,9	B	2 DADOS PASANTES
2A-CC-160-MX	1600	47,65	134,9	D	116	68	115	B	RENAULT-TELMA
2A-CC-170-MX	1700	49,21	154,8	D	123,2	68	130	B	RENAULT-TELMA
2A-CC-180-MX	1800	58,97	167,4	D		79		B	RENAULT



2 DADOS DE ALETA 2 DADOS DE ARILLOS INTERIORES

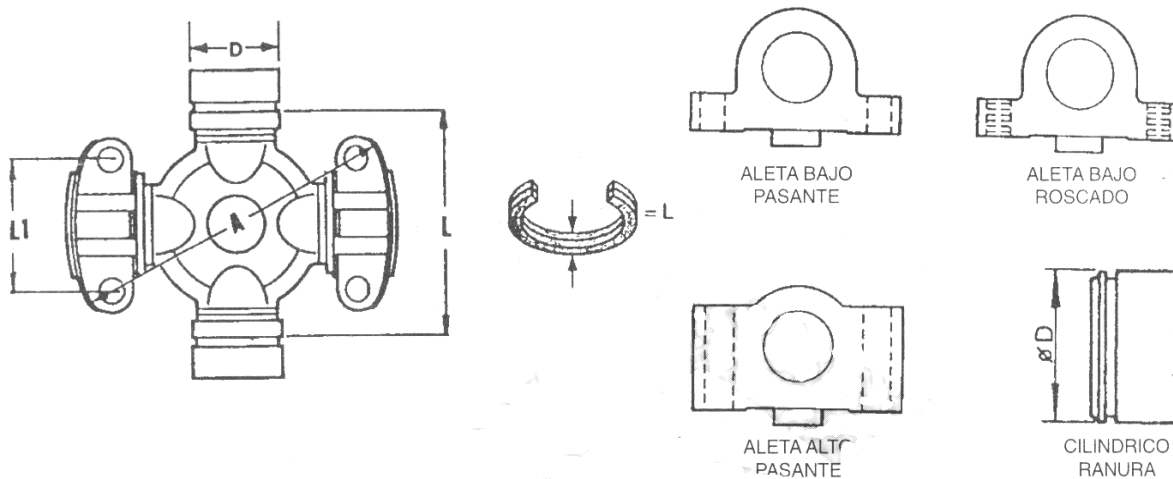

REFERENCIA	SERIE	2 DADOS DE ALETA			2 DADOS CILIN. ARILLOS INTERIORES		OBSERVACIONES
		L1	A	TIPO	DIÁMETRO DADO D	LONG. RANURAS L	
2A-CR-141/4C		33,3	65	BAJO ROSC.	25,4	39,3	
2A-CR-141/4C/R	2C	33,3	79,6	BAJO ROSC.	25,4	55	C/ ENGRASADOR
2A-CR-141/5C		33,3	79,6	BAJO ROSC.	25,4	55	S/ ENGRASADOR
2A-CR-148/5C		33,3	79,6	BAJO PASAN	25,4	55	
2A-CR-148/5C-R	3C	36,5	90,5	BAJO ROSC.	28,6	60	S/ ENGRASADOR
2A-CR-155/6C		36,5	90,5	BAJO ROSC.	28,6	60	C/ ENGRASADOR
2A-CR-155/6C-R	4C	36,5	108	ALTO PASAN	28,6	77,8	
2A-CR-484		36,5	108	BAJO ROSC.	28,6	77,8	
2A-CR-1650/7C	5C	42,9	115	BAJO PASAN	33,3	79,2	
2A-CR-1650/7C-R		42,9	115	BAJO ROSC.	33,3	79,5	
2A-CR-41152/7C	6C	42,9	140	BAJO ROSC.	33,3	105	
2A-CR-170/8,5C		42,9	140	ALTO PASAN	33,3	105	
2A-CR-181/9C	7C	49,2	148,38	ALTO PASAN	41,3	111,13	



2 DADOS ALETA ALTA PASANTE 2 DADOS CILINDRICOS CHAPA SOLDADA

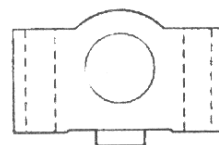
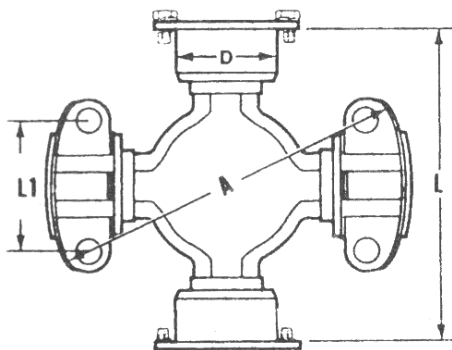

ALETA ALTO PASANTE

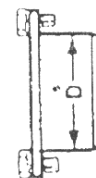

CILINDRICO CHAPA

REFERENCIA	SERIE	2 DADOS ALETA PASANTE		2 DADOS CILIN. CHAPA	
		L1	ANCLAJE A	DIÁMETRO DADO D	L
2A-CR-480	9C/1810	71,4	209,6	49,2	191,5
2A-CR-5-326X	9C/1880	71,4	209,6	55,55	205,6

2 DADOS ABARCONES A DADOS CILINDRICOS RANURA

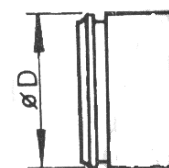
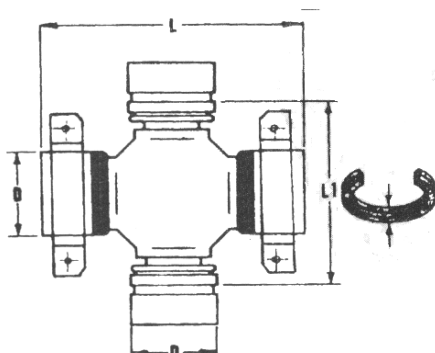

CILINDRICO CON RANURA

REFERENCIA	2 DADOS ABARCONES		2 DADOS CILIN. RANURA	
	ANCLAJE L	L2	DIÁMETRO DADO D	LONG.RANURAS L1
2A-CR-542	110	41,3	29	77,8

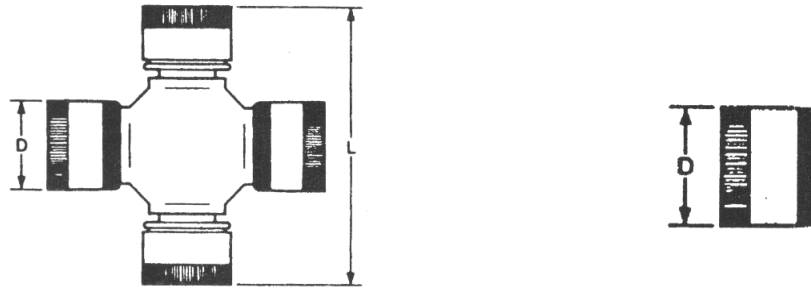

REFERENCIA	4 DADOS CILIN. MOLETEADOS	
	DIÁMETRO DADO D	ANCLAJE L
2A-CR-853	22,2	74
2A-CR-856	25,4	99,3

2 DADOS CILINDRICOS LISOS 2 DADOS CILINDRICOS RANURADOS

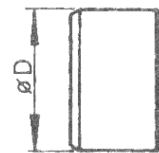
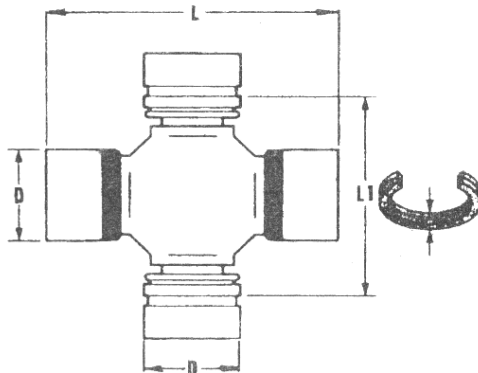

CILINDRICO LISO

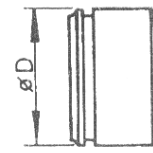

CILINDRICO CON RANURA

REFERENCIA	2 DADOS CILIN. LISOS		2 DADOS CILIN. RANURA	
	DIÁMETRO DADO D	ANCLAJE L	DIÁMETRO DADO D	LONG. RANURAS L1
2A-CR-361	25,4	62,2	27	39
2A-CR-505	27	81,7	25,4	55
2A-CR-497	27	82	28,6	49
2A-CR-434	28,6	92,2	27	67,5



2 DADOS CILINDRICOS RANURA 2 DADOS CILINDRICOS SOLAPA

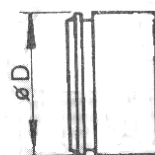
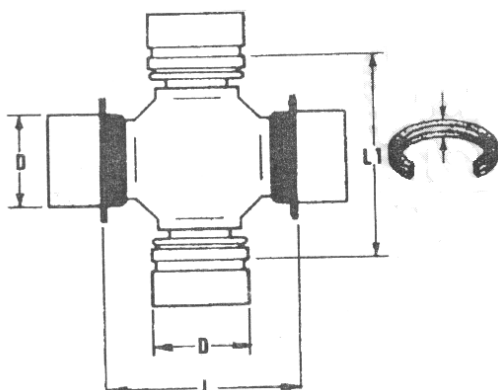

CILINDRICO CON RANURA

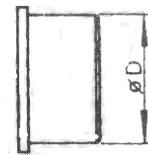

SOLAPA

REFERENCIA	2 DADOS CILIN. RANURA		2 DADOS CILIN. SOLAPA	
	ANCLAJE L1	D	DIÁMETRO DADO D	ANCLAJE L
2A-CR-355	27	67,5	28,6	64,5

2 DADOS CILINDRICOS 2 DADOS CILINDRICOS SOLAPA

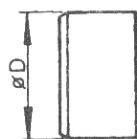
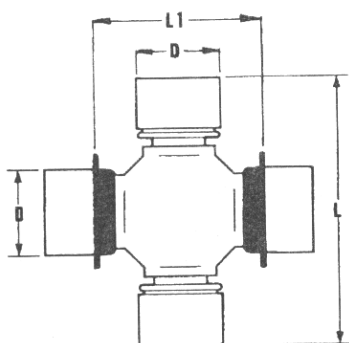

CILINDRICO LISO

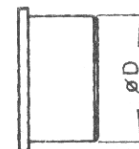

SOLAPA

REFERENCIA	2 DADOS LISOS		2 DADOS CILIN. SOLAPA	
	ANCLAJE D	L	DIÁMETRO DADO D	ANCLAJE L1
2A-CR-350	27	92,2	28,6	54,8
2A-CR-496	27	92,2	28,6	54,8



2 DADOS CILINDRICOS LISOS 2 DADOS CILINDRICOS CHAPAS SOLDADAS

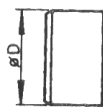
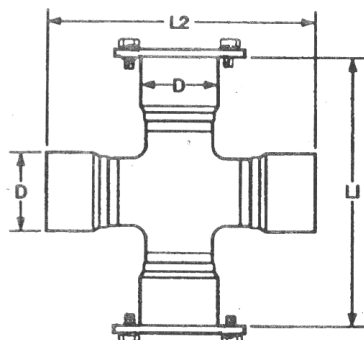

CILINDRICO LISO

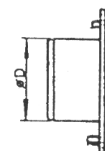

CILINDRICO CHAPA

REFERENCIA	SERIE	2 DADOS CILINDRICOS LISO		2 DADOS CILINDRICOS CHAPA	
		DIÁMETRO DADO D	ANCLAJE L1	DIÁMETRO DADO D	LONG. RANURAS L2
2A-CR-471	1500	39,7	115,9	39,7	115,9
2A-CR-475	1600	47,6	135	47,6	135
2A-CR-476	1700	49,2	154,8	49,2	154,8
2A-CR-477	1760	49,2	177,8	49,2	177,8
2A-CR-478	1810	49,2	191,7	49,2	191,7

4 DADOS CILINDRICOS CHAPAS SOLDADAS

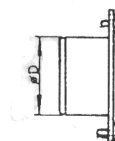
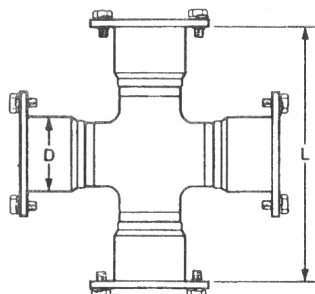

CILINDRICO CHAPA

REFERENCIA	SERIE	4 DADOS CILINDRICOS CHAPA	
		DIÁMETRO DADO D	ANCLAJE L
2A-CR-428	1480	34,9	106,2
2A-CR-915/ 332	1500	39,68	115,9
2A-CR-892		49,2	130
2A-CR-333	1600	47,6	134,9
2A-CR-893		50,8	152
2A-CR-334	1700	49,2	154,8
2A-CR-180	1860	58,97	167,4
2A-CC-176	1760	49,21	177,8
2A-CC-181	1810	49,21	191,5
2A-CR-388		55,6	206
2A-CR-900		46	150,8